

QUESTIONS AND SOLUTIONS OF IIT-JEE 2011

Date : 11-04-2011

Duration : 3 Hours

Max. Marks : 240

PAPER - 2

Please read the instructions carefully. You are allotted 5 minutes specifically for this purpose.

INSTRUCTIONS

A. General :

1. The question paper CODE is printed on the right hand top corner of this sheet and on the back page of this booklet.
2. No additional sheets will be provided for rough work.
3. Blank papers, clipboards, log tables, slide rules, calculators, cellular phones, pagers and electronic gadgets are NOT allowed.
4. Write your name and registration number in the space provided on the back page of this booklet.
5. The answer sheet, a machine-gradable Optical Response Sheet (ORS), is provided separately.
6. DO NOT TAMPER WITH/MUTILATE THE ORS OR THE BOOKLET.
7. Do not break the seals of the question-paper booklet before being instructed to do so by the invigilators.
8. This Question Paper contains having 60 questions.
9. On breaking the seals, please check that all the questions are legible.

B. Filling the Right Part of the ORS:

10. The ORS also has a CODE printed on its Left and Right parts.
11. Make sure the CODE on the ORS is the same as that on this booklet. **If the codes do not match, ask for a change of the booklet.**
12. Write your Name, Registration No. and the name of centre and sign with pen in the boxes provided. **Do not write them anywhere else.** Darken the appropriate bubble **UNDER** each digit of your Registration No. with a **good quality HB pencil.**

C. Question paper format and Marking Scheme:

13. The question paper consists of **3 parts** (Chemistry, Physics and Mathematics). Each part consists of **four sections**.
14. In **Section I** (Total Marks: 24), for each question you will be awarded 3 marks if you darken **ONLY** the bubble corresponding to the correct answer and zero marks if no bubble is darkened. In all other cases, **minus one (-1) mark** will be awarded.
15. In **Section II** (Total Marks: 16), for each question you will be awarded **4 marks** if you darken **ALL** the bubble(s) corresponding to the correct answer(s) **ONLY** and **zero marks** otherwise. There are **no negative marks** in this section.
16. In **Section III** (Total Marks: 24), for each question you will be awarded 4 marks if you darken **ONLY** the bubble corresponding to the correct answer and zero marks otherwise. There are **no negative marks** in this section.
17. In **Section IV** (Total Marks: 16), for each question you will be awarded 2 marks for each row in which you have darkened **ALL** the bubble(s) corresponding to the correct answer(s) **ONLY** and **zero marks** otherwise. Thus, each question in this section carries **a maximum of 8 marks**. There are **no negative marks** in this section.

DO NOT BREAK THE SEALS WITHOUT BEING INSTRUCTED TO DO SO BY THE INVIGILATOR

Write your Name registration number and sign in the space provided on the back page of this booklet.

Useful Data :

$$R = 8.314 \text{ JK}^{-1} \text{ mol}^{-1} \text{ or } 8.206 \times 10^{-2} \text{ L atm K}^{-1} \text{ mol}^{-1}$$

$$1 \text{ F} = 96500 \text{ C mol}^{-1}$$

$$h = 6.626 \times 10^{-34} \text{ Js}$$

$$1 \text{ eV} = 1.602 \times 10^{-19} \text{ J}$$

$$c = 3.0 \times 10^8 \text{ m s}^{-1}$$

$$N_A = 6.022 \times 10^{23}$$

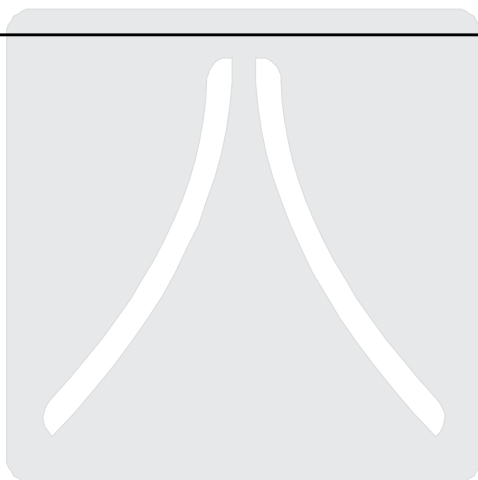

Resonance

Where you will be in resonance with IIT-JEE

PART-II

SECTION – I (Total Marks : 24)

(Single Correct Answer Type)

This section contains 8 multiple choice questions. Each question has four choices (A), (B), (C) and (D) out of which ONLY ONE is correct.

1. Oxidation states of the metal in the minerals haematite and magnetite, respectively, are :
 (A) II, III in haematite and III in magnetite (B) II, III in haematite and II in magnetite
 (C) II in haematite and II, III in magnetite (D) III in haematite and II, III in magnetite

Ans. (D)

- Sol.** In haematite (Fe_2O_3), Fe is present (III) oxidation state and in magnetite (Fe_3O_4) Fe is present in (II) and (III) oxidation state.

2. Among the following complexes (K–P),
 $\text{K}_3[\text{Fe}(\text{CN})_6]$ (K), $[\text{Co}(\text{NH}_3)_6]\text{Cl}_3$ (L), $\text{Na}_3[\text{Co}(\text{oxalate})_3]$ (M), $[\text{Ni}(\text{H}_2\text{O})_6]\text{Cl}_2$ (N), $\text{K}_2[\text{Pt}(\text{CN})_4]$ (O) and $[\text{Zn}(\text{H}_2\text{O})_6](\text{NO}_3)_2$ (P)
 the diamagnetic complexes are :

(A) K, L, M, N (B) K, M, O, P (C) L, M, O, P (D) L, M, N, O

Ans. (C)

- Sol.** $\text{K}-[\text{Fe}(\text{CN})_6]^{3-}$: $3d^5$ electron configuration after pairing of electrons for d^2sp^3 hybridisation it contains one unpaired electrons.
 $\text{L}-[\text{Co}(\text{NH}_3)_6]^{3+}$: $3d^6$ electron configuration, d^2sp^3 , diamagnetic.
 $\text{M}-[\text{Co}(\text{ox})_3]^{3-}$: $3d^6$ electron configuration, d^2sp^3 , diamagnetic.
 $\text{N}-[\text{Ni}(\text{H}_2\text{O})_6]^{2+}$: $3d^8$ electron configuration, sp^3d^2 , with two unpaired electrons ; paramagnetic.
 $\text{O}-[\text{Pt}(\text{CN})_4]^{2-}$: $5d^8$ electron configuration, dsp^2 diamagnetic.
 $\text{P}-[\text{Zn}(\text{H}_2\text{O})_6]^{2+}$: $3d^{10}$ electron configuration, sp^3d^2 diamagnetic.

3. Passing H_2S gas into a mixture of Mn^{2+} , Ni^{2+} , Cu^{2+} and Hg^{2+} ions in an acidified aqueous solution precipitates:
 (A) CuS and HgS (B) MnS and CuS (C) MnS and NiS (D) NiS and HgS

Ans. (A)

- Sol.** In presence of acidic medium, ionisation of H_2S is suppressed so less number of S^{2-} ions are produced. So only those sulphides are precipitated which have low solubility product (K_{sp}) value, For example CuS and HgS .

4. Consider the following cell reaction :

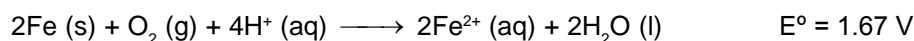

At $[\text{Fe}^{2+}] = 10^{-3} \text{ M}$, $P(\text{O}_2) = 0.1 \text{ atm}$ and $\text{pH} = 3$, the cell potential at 25°C is :

(A) 1.47 V (B) 1.77 V (C) 1.87 V (D) 1.57 V

Ans. (D)

Sol.
$$E = E^{\circ} - \frac{0.059}{4} \log \frac{[\text{Fe}^{2+}]^2}{[\text{H}^+]^4 \text{P}_{\text{O}_2}}$$

$$= 1.67 - \frac{0.06}{4} \log \frac{(10^{-3})^2}{(10^{-3})^4 \times 0.1} = 1.67 - \frac{0.03}{2} \log 10^7$$

$$= 1.67 - \frac{0.03}{2} \times 7 = 1.67 - 0.105 = 1.565 = 1.57 \text{ V.}$$

5. The freezing point (in °C) of a solution containing 0.1 g of $\text{K}_3[\text{Fe}(\text{CN})_6]$ (Mol. Wt. 329) in 100 g of water ($K_f = 1.86 \text{ K g mol}^{-1}$) is :

- (A) -2.3×10^{-2} (B) -5.7×10^{-2} (C) -5.7×10^{-3} (D) -1.2×10^{-2}

Ans. (A)

Sol.
$$\Delta T_f = i \times K_f \times m$$

$$= 4 \times 1.86 \times \frac{0.1}{329 \times 0.1} = 2.3 \times 10^{-2}$$

$\Rightarrow T_f = 0 - 2.3 \times 10^{-2} = -2.3 \times 10^{-2} \text{ } ^\circ\text{C.}$

6. Amongst the compounds given, the one that would form a brilliant colored dye on treatment with NaNO_2 in dilute HCl followed by addition to an alkaline solution of β -naphthol is :

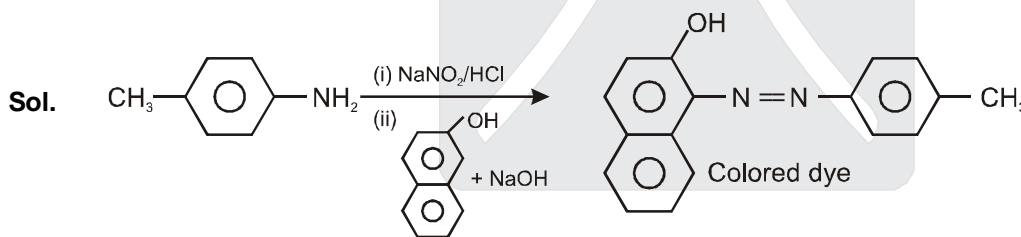
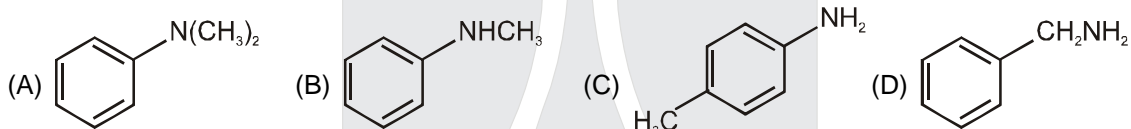

7. The major product of the following reaction is

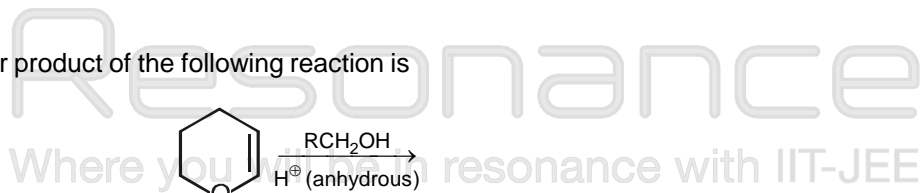

- (A) a hemiacetal (B) an acetal (C) an ether (D) an ester

Ans. (B)

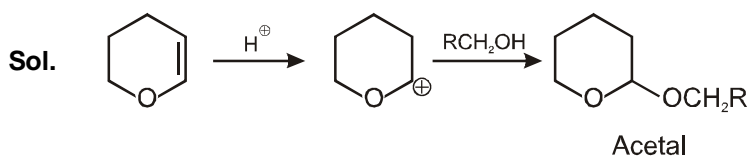

8. The following carbohydrate is

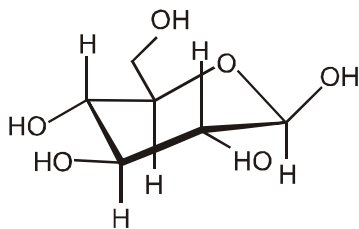

- (A) a ketohexose (B) an aldohexose (C) an α -furanose (D) an α -pyranose

Sol.

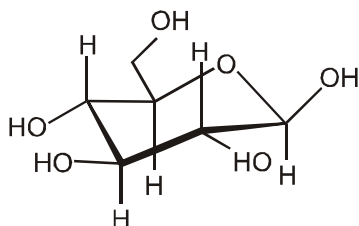

It is a β -pyranose hence it is an aldohexose.

SECTION — II (Total Marks: 16) (Multiple Correct Answer(s) Type)

This section contains **4 multiple choice questions**. Each question has four choices (A), (B), (C) and (D) out of which **ONE or MORE** may be correct.

9. Reduction of the metal centre in aqueous permanganate ion involves.
 (A) 3 electrons in neutral medium (B) 5 electrons in neutral medium
 (C) 3 electrons in alkaline medium (D) 5 electrons in acidic medium

Ans. (A, C, D) / (A, D)

Sol. In acidic medium,



(v.f.=5)

In neutral / basic medium



(v.f.=3)

In strongly basic medium



(v.f.=1)

10. The equilibrium

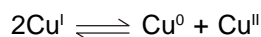

in aqueous medium at 25° C shifts towards the left in the presence of :

- (A) NO_3^- (B) Cl^- (C) SCN^- (D) CN^-

Ans. (B, C, D)

Sol. Cl^- , CN^- , SCN^- ions forms precipitate with Cu^+ .

11. For the first order reaction

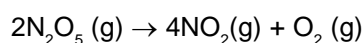

- (A) The concentration of the reaction decreases exponentially with time
 (B) The half-life of the reaction decreases with increasing temperature
 (C) The half-life of the reaction depends on the initial concentration of the reactant
 (D) The reaction proceeds to 99.6% completion in eight half-life duration

Ans. (A, B, D)

Sol. $C_t = C_0 e^{-kt}$

$$t_{1/2} \propto \frac{1}{K}, \quad K \uparrow \text{ on increasing T.}$$

After eight half lives,

$$C = \frac{C_0}{2^8}$$

$$\Rightarrow \% \text{ completion} = \frac{C_0 - \frac{C_0}{2^8}}{C_0} \times 100 = 99.6\%$$

12. The correct functional group X and the reagent/reaction conditions Y in the following scheme are

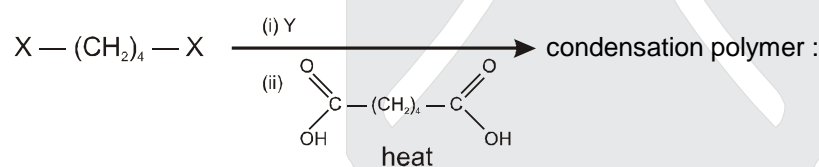

- (A) $\text{X} = \text{COOCH}_3$, $\text{Y} = \text{H}_2/\text{Ni}/\text{heat}$ (B) $\text{X} = \text{CONH}_2$, $\text{Y} = \text{H}_2/\text{Ni}/\text{heat}$
 (C) $\text{X} = \text{CONH}_2$, $\text{Y} = \text{Br}_2/\text{NaOH}$ (D) $\text{X} = \text{CN}$, $\text{Y} = \text{H}_2/\text{Ni}/\text{heat}$

Sol. (A) $\text{CH}_3\text{OOC} - (\text{CH}_2)_4 - \text{COOCH}_3 \xrightarrow[\Delta]{\text{H}_2/\text{Ni}} \text{HOCH}_2 - (\text{CH}_2)_4 - \text{CH}_2 - \text{OH} \xrightarrow[\Delta]{\text{HOOC} - (\text{CH}_2)_4 - \text{COOH}}$

Where you will be in resonance with IIT-JEE

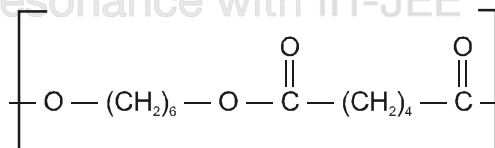

(B) $\text{NH}_2\text{OC} - (\text{CH}_2)_4 - \text{CONH}_2 \xrightarrow[\Delta]{\text{H}_2/\text{Ni}} \text{NH}_2 - (\text{CH}_2)_6 - \text{NH}_2 \xrightarrow[\Delta]{\text{HOOC} - (\text{CH}_2)_4 - \text{COOH}}$

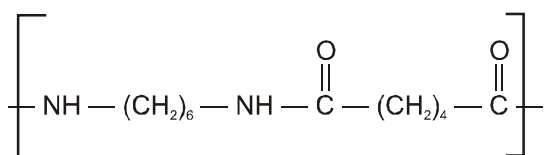
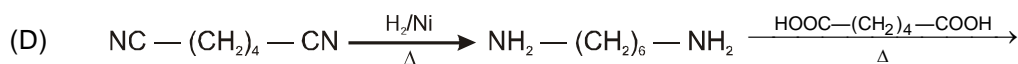
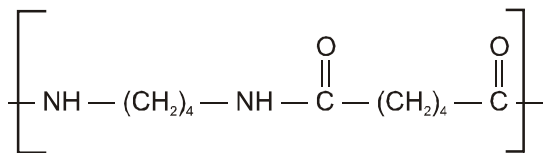
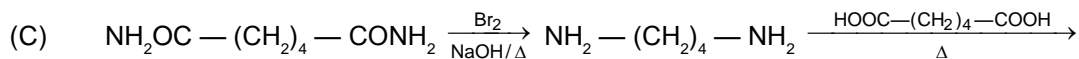
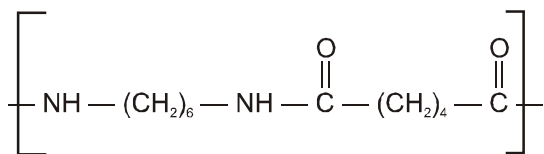

Section III (Total Marks : 24)
(Integer Answer Type)

This section contains 6 questions. The answer to each of the questions is a single-digit integer, ranging from 0 to 9. The bubble corresponding to the correct answer is to be darkened in the ORS.

13. Among the following, the number of compounds that can react with PCl_5 to give POCl_3 is O_2 , CO_2 , SO_2 , H_2O , H_2SO_4 , P_4O_{10} .

Ans. 4

- Sol.** PCl_5 produces POCl_3 on reaction with these compounds

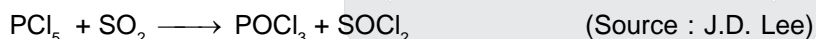

14. The volume (in mL) of 0.1 M AgNO_3 required for complete precipitation of chloride ions present in 30 mL of 0.01 M solution of $[\text{Cr}(\text{H}_2\text{O})_5\text{Cl}]\text{Cl}_2$, as silver chloride is close to.

Ans. 6

- Sol.** m moles of $[\text{Cr}(\text{H}_2\text{O})_5\text{Cl}]\text{Cl}_2 = 0.01 \times 30 = 0.3$.

$$\Rightarrow \text{mmole of Cl}^- = 0.3 \times 2 = 0.6$$

$$\Rightarrow \text{mmole of Ag}^+ = \text{mmoles of Cl}^-$$

$$\Rightarrow 0.1 \times V = 0.6$$

$$\Rightarrow V = 6 \text{ mL.}$$

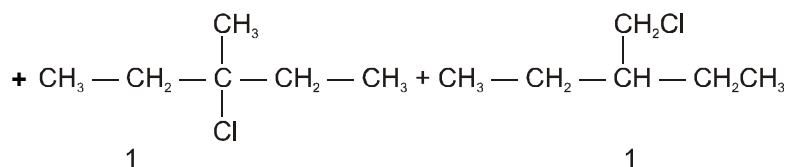

Total = 8

18. The total number of contributing structures showing hyperconjugation (involving C–H bonds) for the following carbocation is

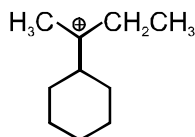

Ans. 6

- Sol. There are total 6 hyperconjugable H-atoms in this carbocation which are contributing in the hyperconjugation.

SECTION — IV (Total Marks : 16)

(Matrix-Match Type)

This section contains 2 questions. Each question has four statements (A, B, C and D) given in Column I and five statements (p, q, r, s and t) in Column II. Any given statement in Column I can have correct matching with ONE or MORE statement(s) given in Column II. For example, if for a given question, statement B matches with the statements given in q and r, then for the particular question, against statement B, darken the bubbles corresponding to q and r in the ORS.

19. Match the transformation in **column I** with appropriate options in **column II**

Column I	Column II
(A) $\text{CO}_2(\text{s}) \longrightarrow \text{CO}_2(\text{g})$	(p) phase transition
(B) $\text{CaCO}_3(\text{s}) \longrightarrow \text{CaO}(\text{s}) + \text{CO}_2(\text{g})$	(q) allotropic change
(C) $2\text{H}\cdot \longrightarrow \text{H}_2(\text{g})$	(r) ΔH is positive
(D) $\text{P}_{(\text{white, solid})} \longrightarrow \text{P}_{(\text{red, solid})}$	(s) ΔS is positive
	(t) ΔS is negative

Ans. (A – p, r, s) ; (B – r, s) ; (C – t) ; (D – p, q, t)

- Sol. (A) $\text{CO}_2(\text{s}) \longrightarrow \text{CO}_2(\text{g})$

It is phase transition. The process is endothermic (sublimation).
Gas is produced, so entropy increases.

(B) On heating CaCO_3 decomposes. So, process is endothermic.
The entropy increases as gaseous product is formed.

(C) $2\text{H}\cdot \longrightarrow \text{H}_2(\text{g})$

Entropy decreases as number of gaseous particles decreases.

(D) It is phase transition.

White and red P are allotopes.

Red P is more stable than white.

So ΔH is – ve.

20. Match the reactions in **column I** with appropriate type of steps/reactive intermediate involved in these reactions as given in **column II**

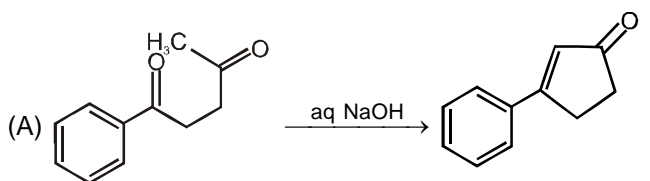
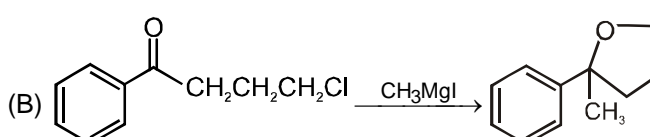
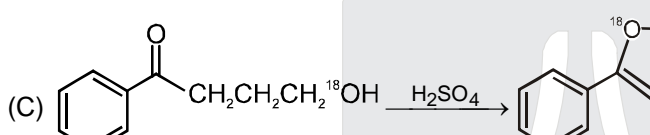
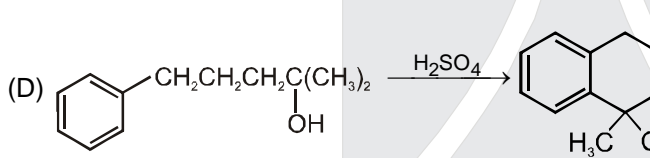
Column I	Column II
<p>(A) </p>	<p>(p) Nucleophilic substitution</p>
<p>(B) </p>	<p>(q) Electrophilic substitution</p>
<p>(C) </p>	<p>(r) Dehydration</p>
<p>(D) </p>	<p>(s) Nucleophilic addition</p>
	<p>(t) Carbanion</p>

Ans. (A-r, s, t) ; (B-p, s) ; (C-r, s) ; (D-q, r)

Resonance

Where you will be in resonance with IIT-JEE

Sol. (A)

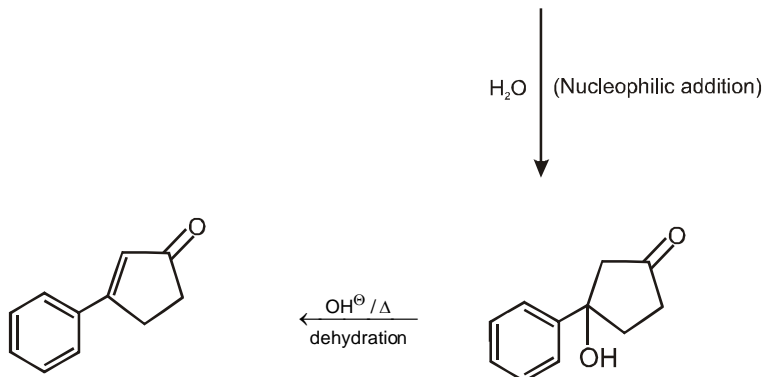
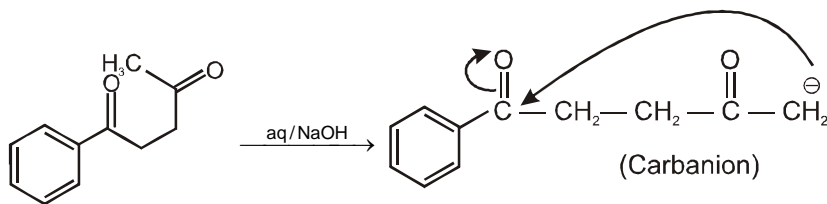

(B)

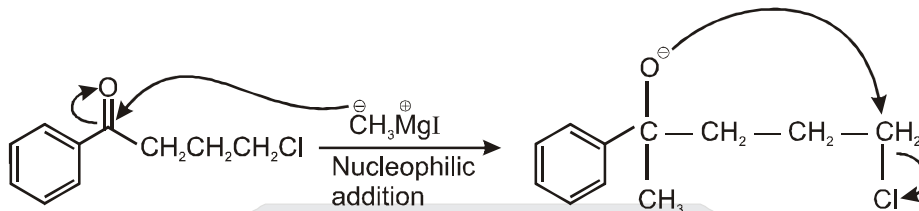

(C)

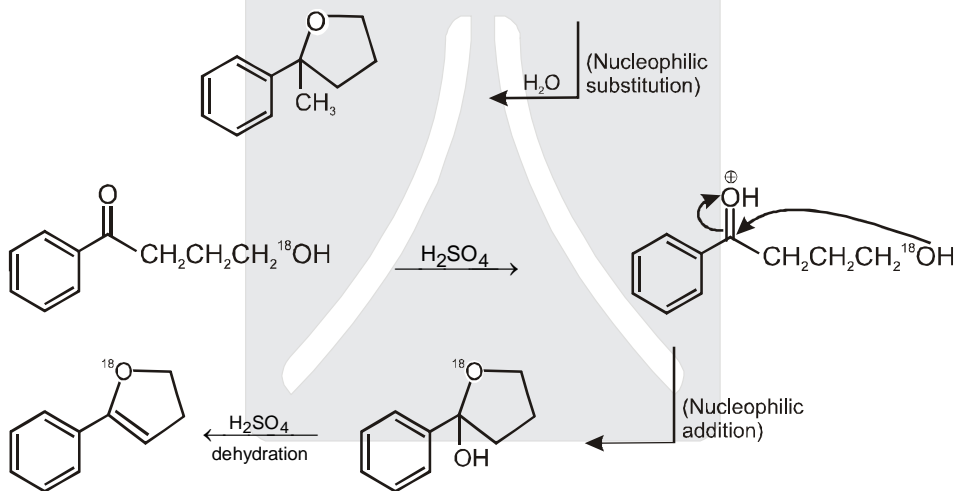

(D)

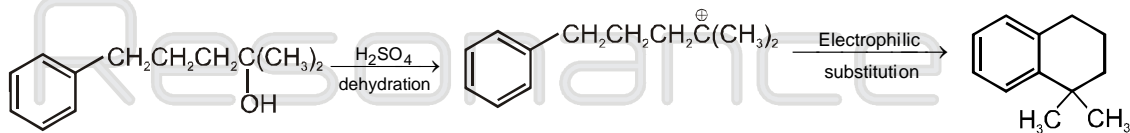

Where you will be in resonance with IIT-JEE

PART-II
SECTION - I (Total Marks - 24)
(Single Correct Answer Type)

This section contains **8 multiple choice questions**. Each question has four choices **(A), (B), (C)** and **(D)** out of which **ONLY ONE** is correct.

21. A light ray traveling in glass medium is incident on glass-air interface at an angle of incidence θ . The reflected (R) and transmitted (T) intensities, both as function of θ , are plotted. The correct sketch is

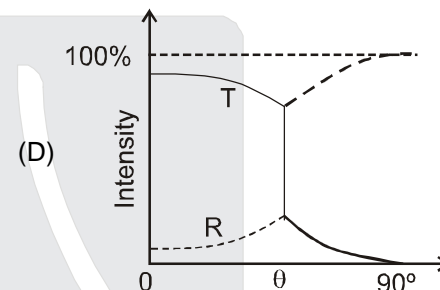
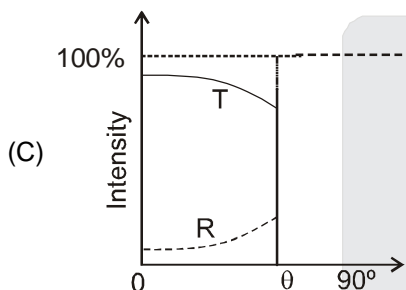
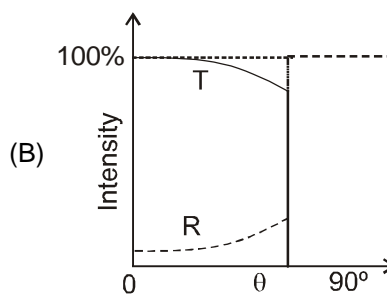
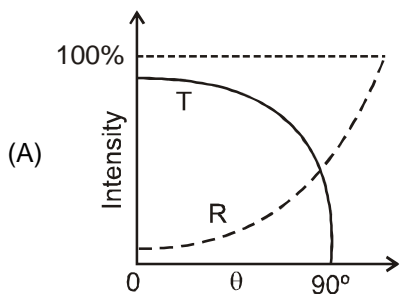

Ans. (C)

Sol. (C)



Initially most of part will be transmitted. When $\theta > i_c$, all the light rays will be total internal reflected. So transmitted intensity = 0
 So correct answer is (C)

22. A satellite is moving with a constant speed 'V' in a circular orbit about the earth. An object of mass 'm' is ejected from the satellite such that it just escapes from the gravitational pull of the earth. At the time of its ejection, the kinetic energy of the object is

- (A) $\frac{1}{2}mV^2$ (B) mV^2 (C) $\frac{3}{2}mV^2$ (D) $2mV^2$

Ans. (B)

Sol. (B)

$$V_e = \sqrt{2}V_0$$

$$KE = \frac{1}{2}mv_e^2 = \frac{1}{2}m(\sqrt{2}V_0)^2 = mV_0^2$$

23. A long insulated copper wire is closely wound as a spiral of 'N' turns. The spiral has inner radius 'a' and outer radius 'b'. The spiral lies in the X-Y plane and a steady current I flows through the wire. The Z-component of the magnetic field at the center of the spiral is

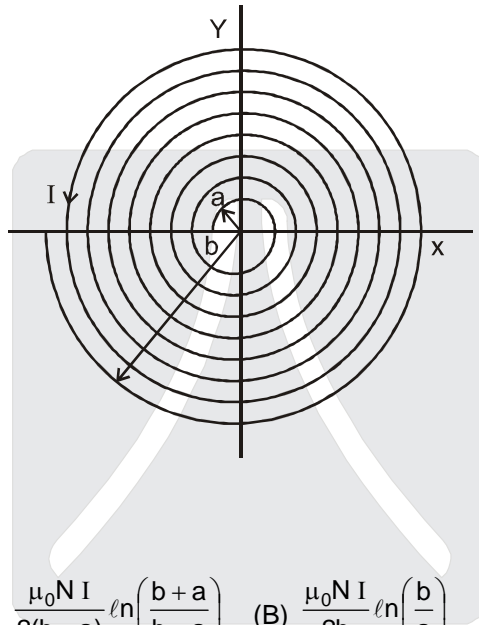

- (A) $\frac{\mu_0 N I}{2(b-a)} \ln\left(\frac{b}{a}\right)$ (B) $\frac{\mu_0 N I}{2(b-a)} \ln\left(\frac{b+a}{b-a}\right)$ (C) $\frac{\mu_0 N I}{2b} \ln\left(\frac{b}{a}\right)$ (D) $\frac{\mu_0 N I}{2b} \ln\left(\frac{b+a}{b-a}\right)$

Ans. (A)

Sol.
$$B = \int \frac{\mu_0 dNi}{2x} = \int \frac{\mu_0 \left(\frac{N}{b-a} dx\right) i}{2x} = \frac{\mu_0 Ni}{2(b-a)} \ln \frac{b}{a}$$

24. A point mass is subjected to two simultaneous sinusoidal displacements in x-direction, $x_1(t) = A \sin \omega t$ and

$x_2(t) = A \sin \left(\omega t + \frac{2\pi}{3}\right)$. Adding a third sinusoidal displacement $x_3(t) = B \sin(\omega t + \phi)$ brings the mass to a

complete rest. The values of B and ϕ are

- (A) $\sqrt{2}A, \frac{3\pi}{4}$ (B) $A, \frac{4\pi}{3}$ (C) $\sqrt{3}A, \frac{5\pi}{6}$ (D) $A, \frac{\pi}{3}$

Ans. (B)

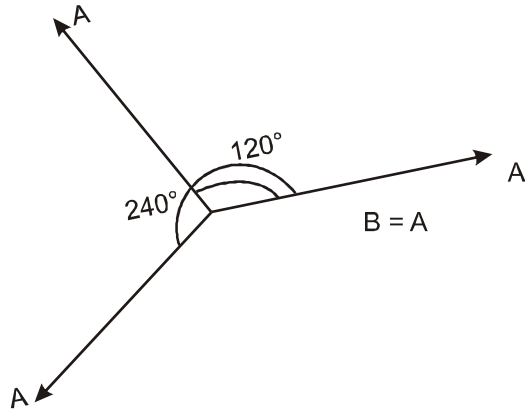

So $B = A, \phi = 240^\circ = \frac{4\pi}{3}$

25. Which of the field patterns given below is valid for electric field as well as for magnetic field?

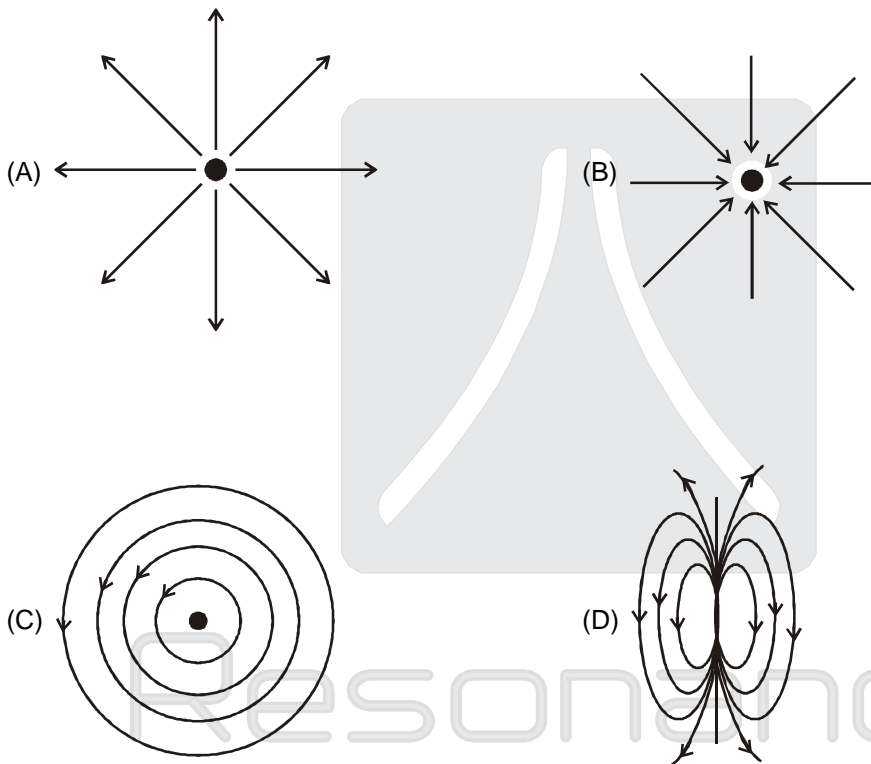

Resonance
Where you will be in resonance with IIT-JEE

Ans. (C)

Sol. True for induced electric field and magnetic field.

26. A ball of mass 0.2 kg rests on a vertical post of height 5 m. A bullet of mass 0.01 kg, traveling with a velocity V m/s in a horizontal direction, hits the centre of the ball. After the collision, the ball and bullet travel independently. The ball hits the ground at a distance of 20 m and the bullet at a distance of 100 m from the foot of the post. The initial velocity V of the bullet is

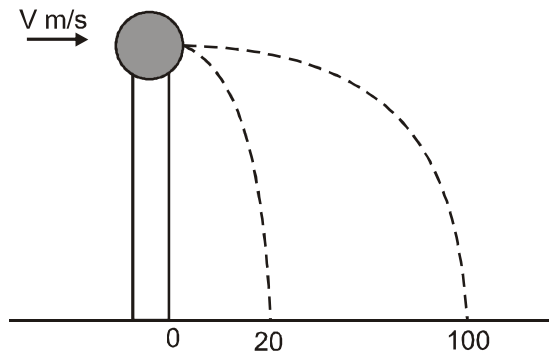

- (A) 250 m/s (B) $250\sqrt{2}$ m/s (C) 400 m/s (D) 500 m/s

Ans. (D)

Sol.
$$R = u \sqrt{\frac{2h}{g}}$$

$$\Rightarrow 20 = V_1 \sqrt{\frac{2 \times 5}{10}} \text{ and } 100 = V_2 \sqrt{\frac{2 \times 5}{10}}$$

$$\Rightarrow V_1 = 20 \text{ m/s}, V_2 = 100 \text{ m/sec.}$$

Applying momentum conservation just before and just after the collision

$$(0.01)(V) = (0.2)(20) + (0.01)(100)$$

$$V = 500 \text{ m/s}$$

27. The density of a solid ball is to be determined in an experiment. The diameter of the ball is measured with a screw gauge, whose pitch is 0.5 mm and there are 50 divisions on the circular scale. The reading on the main scale is 2.5 mm and that on the circular scale is 20 divisions. If the measured mass of the ball has a relative error of 2%, the relative percentage error in the density is

- (A) 0.9% (B) 2.4% (C) 3.1% (D) 4.2%

Ans. (C)

Sol. Least count = $\frac{0.5}{50} = 0.01$ mm

$$\text{Diameter of ball } D = 2.5 \text{ mm} + (20)(0.01)$$

$$D = 2.7 \text{ mm}$$

$$\rho = \frac{M}{\text{vol}} = \frac{M}{\frac{4}{3}\pi\left(\frac{D}{2}\right)^3}$$

$$\left(\frac{\Delta\rho}{\rho}\right)_{\max} = \frac{\Delta m}{m} + 3\frac{\Delta D}{D} ; \quad \left(\frac{\Delta\rho}{\rho}\right)_{\max} = 2\% + 3\left(\frac{0.01}{2.7}\right) \times 100\%$$

$$\frac{\Delta\rho}{\rho} = 3.1\%$$

28. A wooden block performs SHM on a frictionless surface with frequency, ν_0 . The block carries a charge $+Q$ on its surface. If now a uniform electric field E is switched-on as shown, then the SHM of the block will be

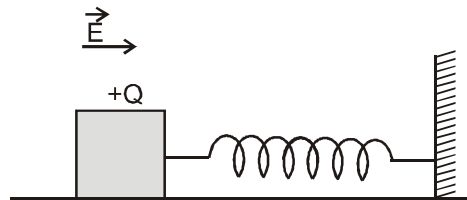

- (A) of the same frequency and with shifted mean position.
 (B) of the same frequency and with the same mean position.
 (C) of changed frequency and with shifted mean position.
 (D) of changed frequency and with the same mean position.

Ans. (A)

Sol. The frequency will be same $f = \frac{1}{2\pi} \sqrt{\frac{k}{m}}$

but due to the constant qE force, the equilibrium position gets shifted by $\frac{qE}{K}$ in forward direction. So Ans. will be (A)

SECTION — II (Total Marks: 16) (Multiple Correct Answer(s) Type)

This section contains 4 multiple choice questions. Each question has four choices (A), (B), (C) and (D) out of which ONE or MORE may be correct.

29. Two solid spheres A and B of equal volumes but of different densities d_A and d_B are connected by a string. They are fully immersed in a fluid of density d_f . They get arranged into an equilibrium state as shown in the figure with a tension in the string. The arrangement is possible only if

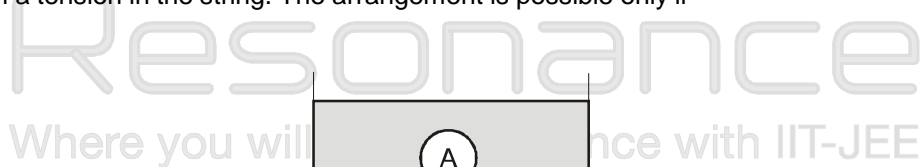

- (A) $d_A < d_f$ (B) $d_B > d_f$ (C) $d_A > d_f$ (D) $d_A + d_B = 2d_f$

Ans. (A), (B), (D)

Sol.

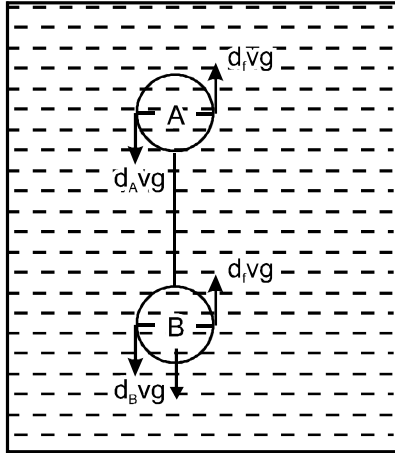

For equilibrium

$$d_A vg + d_B vg = d_f vg + d_f vg$$

$$\Rightarrow d_F = \frac{d_A + d_B}{2} \Rightarrow \text{Option (D) is correct}$$

to keep the string tight

$$d_B > d_F \text{ and } d_A < d_F$$

30. A series R-C circuit is connected to AC voltage source. Consider two cases; (A) when C is without a dielectric medium and (B) when C is filled with dielectric of constant 4. The current I_R through the resistor and voltage V_C across the capacitor are compared in the two cases. Which of the following is/are true?

- (A) $I_R^A > I_R^B$ (B) $I_R^A < I_R^B$ (C) $V_C^A > V_C^B$ (D) $V_C^A < V_C^B$

Ans. (B), (C)

Sol.

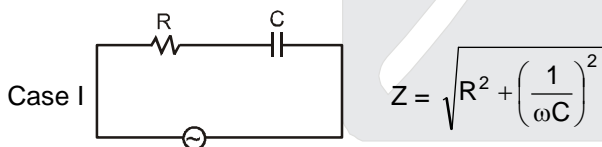

$$I_R^A = \frac{V}{Z} \quad Z' < Z$$

$$I_R^B = \frac{V}{Z'} \quad I_R^A < I_R^B$$

$$V_R^A < V_R^B$$

So. $V_C^A > V_C^B \quad \because \quad V_R^2 + V_C^2 = V_0^2$

31. Which of the following statement(s) is/are correct?
 (A) If the electric field due to a point charge varies as $r^{-2.5}$ instead of r^{-2} , then the Gauss law will still be valid.
 (B) The Gauss law can be used to calculate the field distribution around an electric dipole.
 (C) If the electric field between two point charges is zero somewhere, then the sign of the two charges is the same.
 (D) The work done by the external force in moving a unit positive charge from point A at potential V_A to point B at potential V_B is $(V_B - V_A)$.

Ans. (C)

Sol. $\phi = \int E ds = \frac{Kq}{r^2} 4\pi r^2 = \frac{q}{\epsilon_0}$

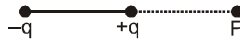

$W_{\text{ext}} = q(V_B - V_A)$

Comment : (D) is not correct answer because it is not given that charge is moving slowly.

32. A thin ring of mass 2 kg and radius 0.5 m is rolling without slipping on a horizontal plane with velocity 1 m/s. A small ball of mass 0.1 kg, moving with velocity 20 m/s in the opposite direction, hits the ring at a height of 0.75 m and goes vertically up with velocity 10 m/s. Immediately after the collision

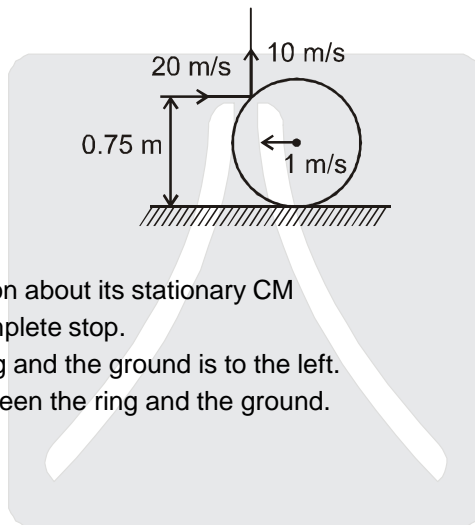

- (A) The ring has pure rotation about its stationary CM
 (B) The ring comes to a complete stop.
 (C) Friction between the ring and the ground is to the left.
 (D) There is no friction between the ring and the ground.

Ans. (C)

Sol. Friction force on the ring.

Section — III (Total Marks : 24)
(Integer Answer Type)

This section contains 6 questions. The answer to each of the questions is a single-digit integer, ranging from 0 to 9. The bubble corresponding to the correct answer is to be darkened in the ORS.

33. A train is moving along a straight line with a constant acceleration 'a'. A boy standing in the train throws a ball forward with a speed of 10 m/s, at an angle of 60° to the horizontal. The boy has to move forward by 1.15 m inside the train to catch the ball back at the initial height. The acceleration of the train, in m/s^2 , is

Ans. 5

Sol. $T = \frac{2u \sin \theta}{g}$

$$T = \frac{2 \times 10 \times \sqrt{3}}{10 \times 2} = \sqrt{3} \text{ sec}$$

$$R = u \cos \theta \cdot T - \frac{1}{2} a T^2$$

$$1.15 = 10 \times \frac{1}{2} \sqrt{3} - \frac{1}{2} a (\sqrt{3})^2$$

$$\frac{3}{2} a = 5\sqrt{3} - 1.15$$

$$\frac{3a}{2} = 8.65 - 1.15 = 7.5$$

$$a = 7.5 \times \frac{2}{3} \approx 5 \text{ m/sec}^2$$

$$a = 5 \text{ m/sec}^2$$

34. A block of mass 0.18 kg is attached to a spring of force-constant 2 N/m. The coefficient of friction between the block and the floor is 0.1. Initially the block is at rest and the spring is un-stretched. An impulse is given to the block as shown in the figure. The block slides a distance of 0.06 m and comes to rest for the first time. The initial velocity of the block in m/s is $V = N/10$. Then N is

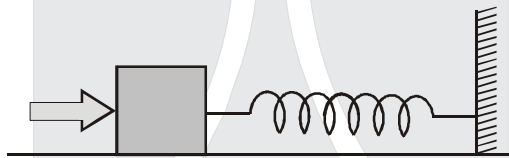

Ans. 4

Sol.

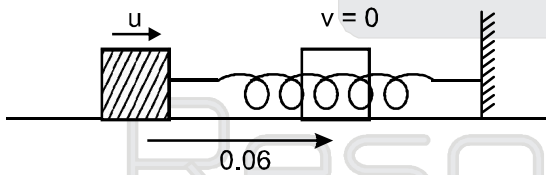

$$\mu = 0.1$$

$$\frac{1}{2} m u^2 = \mu m g \times 0.06 + \frac{1}{2} k x^2$$

$$\frac{1}{2} \times 0.18 u^2 = 0.1 \times 0.18 \times 10 \times 0.06$$

$$0.4 = \frac{N}{10}$$

$$N = 4 \text{ Ans.}$$

35. Two batteries of different emfs and different internal resistances are connected as shown. The voltage across AB in volts is

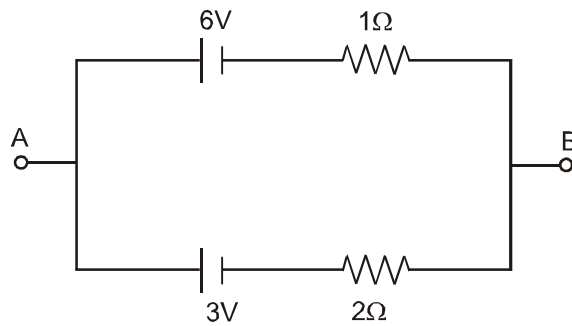

Ans. 5

Sol.

$$\varepsilon = \frac{\frac{E_1 + E_2}{\frac{1}{r_1} + \frac{1}{r_2}}}{\frac{1}{r_1} + \frac{1}{r_2}} = \frac{\frac{6 + 3}{\frac{1}{1} + \frac{1}{2}}}{\frac{1}{1} + \frac{1}{2}}$$

$$= \frac{15}{3} = 5 \text{ volt}$$

Ans.

36. Water (with refractive index = $\frac{4}{3}$) in a tank is 18 cm deep. Oil of refractive index $\frac{7}{4}$ lies on water making a convex surface of radius of curvature 'R = 6 cm' as shown. Consider oil to act as a thin lens. An object 'S' is placed 24 cm above water surface. The location of its image is at 'x' cm above the bottom of the tank. Then 'x' is

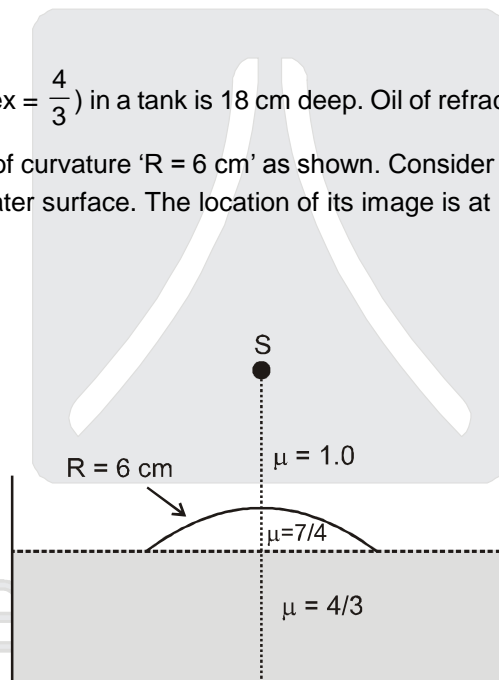

Ans. 2

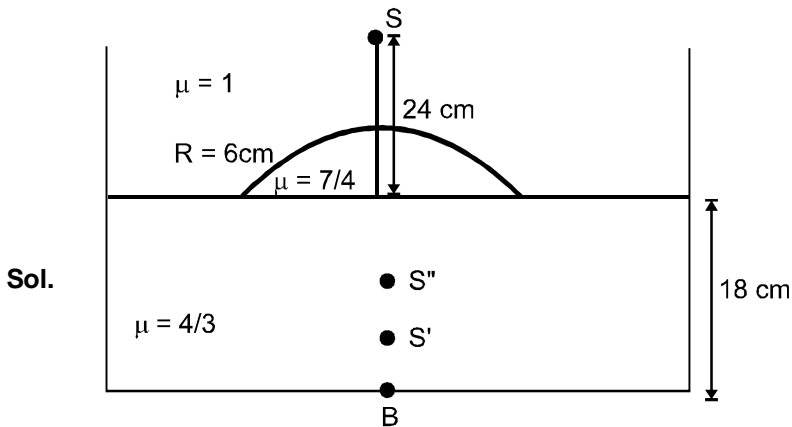

$$\frac{\mu_2}{v} - \frac{\mu_1}{u} = \frac{\mu_2 - \mu_1}{R}$$

$$\frac{7}{4v} - \frac{1}{-24} = \frac{7/4 - 1}{6}$$

$$\frac{7}{4v} = \frac{3}{24} - \frac{1}{24} = \frac{2}{24} = \frac{1}{12}$$

$$\frac{7 \times 12}{4} = v = 21 \text{ cm}$$

$$\frac{21}{OS''} = \frac{7/4}{4/3}$$

$$\frac{21}{OS''} = \frac{7}{4} \times \frac{3}{4}$$

$$OS'' = 16$$

$$\therefore BS'' = 2 \text{ cm}$$

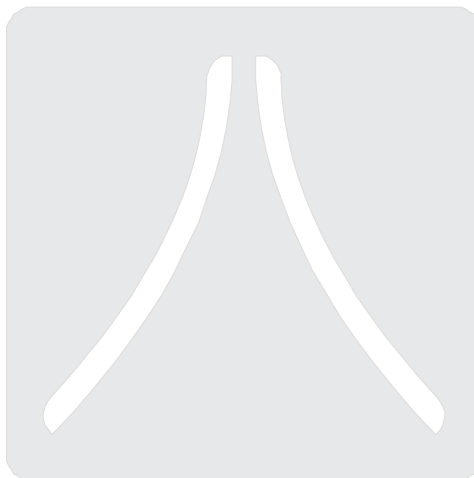

37. A series R-C combination is connected to an AC voltage of angular frequency $\omega = 500$ radian/s. If the impedance of the R-C circuit is $R\sqrt{1.25}$, the time constant (in millisecond) of the circuit is

Ans. 4

Resonance
Where you will be in resonance with IIT-JEE

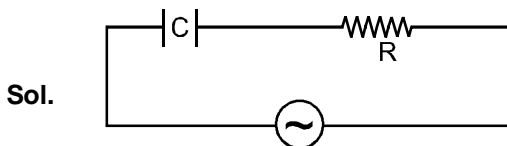

$$\omega = 500 \text{ rad/s}$$

$$Z = \sqrt{\left(\frac{1}{\omega L}\right)^2 + R^2} = R\sqrt{1.25}$$

$$\left(\frac{1}{\omega L}\right)^2 + R^2 = R^2 \quad (1.25)$$

$$\left(\frac{1}{\omega L}\right)^2 + R^2 = R^2 + \frac{R^2}{4}$$

$$\Rightarrow \frac{1}{\omega L} = \frac{R}{2}$$

$$CR = \frac{2}{\omega} = \frac{2}{500} \text{ sec.}$$

$$= \frac{2}{500} \times 10^3 \text{ ms}$$

$$= \frac{2 \times 1000}{500} \text{ ms}$$

$$= 4 \text{ ms}$$

38. A silver sphere of radius 1 cm and work function 4.7 eV is suspended from an insulating thread in free-space. It is under continuous illumination of 200 nm wavelength light. As photoelectrons are emitted, the sphere gets charged and acquires a potential. The maximum number of photoelectrons emitted from the sphere is $A \times 10^Z$ (where $1 < A < 10$). The value of 'Z' is

Ans. 7

Sol.

$$R = 1 \text{ cm}$$

$$f = 4.7 \text{ eV}$$

$$\frac{hc}{\lambda} = \phi + eV$$

$$\frac{1240(\text{eV})(\text{nm})}{200(\text{nm})} = 4.7 (\text{eV}) + eV$$

$$\frac{1240}{200} e = 4.7 e + eV$$

$$6.2 - 4.7 = V \quad \therefore V = 1.5 \text{ volt}$$

$$\frac{1}{4\pi\epsilon_0} \frac{Q}{R} = 1.5$$

$$(9 \times 10^9) \frac{Ne}{100} = 1.5$$

$$9 \times 10^{11} Ne = 1.5 \quad ; \quad N = \frac{1.5}{9 \times 10^{11} \times 1.6 \times 10^{-19}} = \frac{15}{16} \times \frac{1}{9} \times 10^8$$

$$= \frac{5}{3 \times 16} \times 10^8 = \frac{50}{48} \times 10^7$$

$$\therefore Z = 7$$

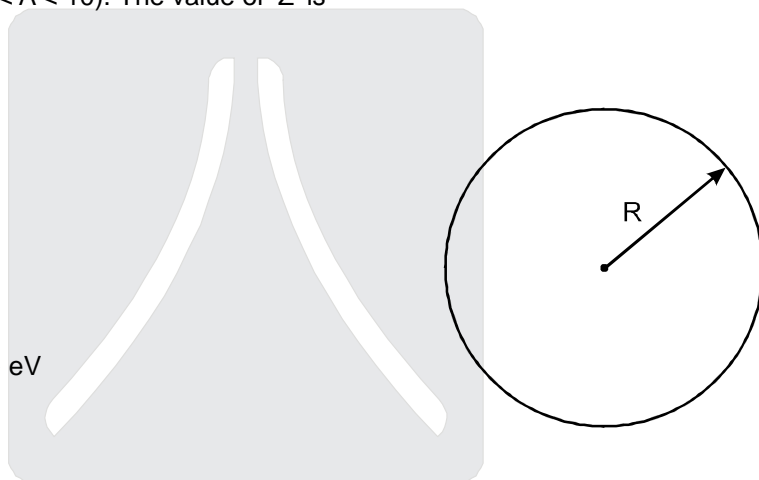

Resonance

Where you will be in resonance with IIT-JEE

SECTION — IV (Total Marks : 16)

(Matrix-Match Type)

This section contains 2 questions. Each question has four statements (A, B, C and D) given in Column I and five statements (p, q, r, s and t) in Column II. Any given statement in Column I can have correct matching with ONE or MORE statement(s) given in Column II. For example, if for a given question, statement B matches with the statements given in q and r, then for the particular question, against statement B, darken the bubbles corresponding to q and r in the ORS.

39. One mole of a monatomic ideal gas is taken through a cycle ABCDA as shown in the P-V diagram. Column II gives the characteristics involved in the cycle. Match them with each of the processes given in Column I.

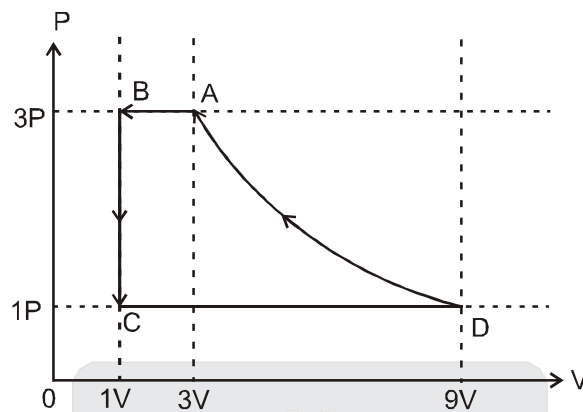

- Column I
 (A) Process A → B
 (B) Process B → C
 (C) Process C → D
 (D) Process D → A

- Column II
 (p) Internal energy decreases
 (q) Internal energy increases
 (r) Heat is lost
 (s) Heat is gained
 (t) Work is done on the gas.

Ans. (A) – p,r,t, (B) – p,r (C) – q,s, (D) – r, t

Sol. A → B ⇒ V ↓ P const ⇒ T ↓ U ↓ (p), (r), (t)

B → C ⇒ $d\omega \downarrow 0$
 P ↓ T ↓
 $d\phi = du + d\omega$ (p), (r)

C → D ⇒ V ↑ ⇒ T ↑
 $du \Rightarrow +ve$
 $d\omega = +ve$ (q), (s)

D → A ⇒ $d\omega \Rightarrow -ve$ (r), (t)
 $dq \Rightarrow -ve$
 $du = 0$

40. Column I shows four systems, each of the same length L , for producing standing waves. The lowest possible natural frequency of a system is called its fundamental frequency, whose wavelength is denoted as λ_f . Match each system with statements given in Column II describing the nature and wavelength of the standing waves.

Column I

Column II

- (A) Pipe closed at one end

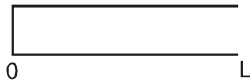

- (p) Longitudinal waves

- (B) Pipe open at both ends

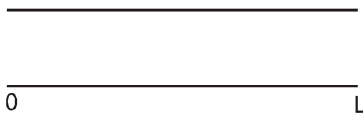

- (q) Transverse waves

- (C) Stretched wire clamped at both ends



- (r) $\lambda_f = L$

- (D) Stretched wire clamped at both ends and at mid-point

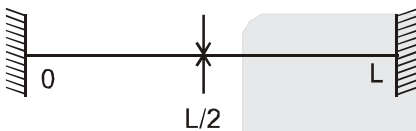

- (s) $\lambda_f = 2L$

- (t) $\lambda_f = 4L$

Ans. (A) – p,t, (B) – p,s, (C) – q,s, (D) – q, r

Sol.

(A) $\frac{\lambda}{4} = L, \lambda = 4L,$

Sound waves are longitudinal waves

(B) $\frac{\lambda}{2} = L, \lambda = 2L$

Sound waves are longitudinal waves

(C) $\frac{\lambda}{2} = L, \lambda = 2L$

String waves are transverse waves

(D) $\lambda = L$

String waves are transverse waves

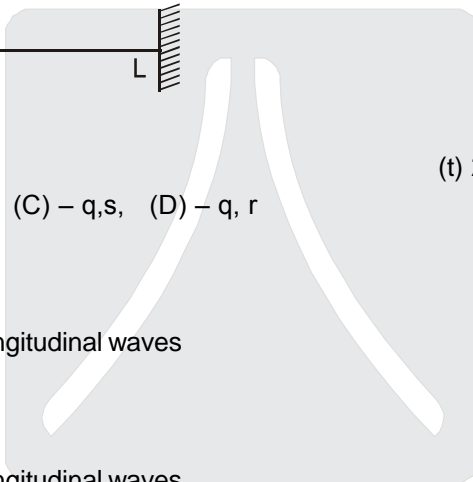

Resonance
Where you will be in resonance with IIT-JEE

PART - III

SECTION - I (Total Marks : 24)
(Single Correct Answer Type)

This section contains **8 multiple choice questions**. Each question has four choices (A), (B), (C) and (D) out of which **ONLY ONE** is correct.

41. Let P(6, 3) be a point on the hyperbola $\frac{x^2}{a^2} - \frac{y^2}{b^2} = 1$. If the normal at the point P intersects the x-axis at (9, 0), then the eccentricity of the hyperbola is

- (A) $\sqrt{\frac{5}{2}}$ (B) $\sqrt{\frac{3}{2}}$ (C) $\sqrt{2}$ (D) $\sqrt{3}$

Ans. (B)

Sol. Equation of normal at P(6, 3)

$$\frac{a^2x}{6} - \frac{b^2y}{3} = a^2 + b^2$$

It passes through (9, 0)

$$\frac{3}{2}a^2 = a^2 + b^2 \Rightarrow \frac{3}{2} = \frac{a^2 + b^2}{a^2} = 1 + \frac{b^2}{a^2}$$

$$\Rightarrow e = \sqrt{1 + \frac{b^2}{a^2}} = \sqrt{\frac{3}{2}}$$

42. A value of b for which the equations $x^2 + bx - 1 = 0$
 $x^2 + x + b = 0$
have one root in common is

- (A) $-\sqrt{2}$ (B) $-i\sqrt{3}$ (C) $i\sqrt{5}$ (D) $\sqrt{2}$

Ans. (B)

Sol.

$$\frac{x^2 + bx - 1 = 0}{x^2 + x + b = 0}$$

$$\frac{x^2}{b^2 + 1} = \frac{x}{-1 - b} = \frac{1}{1 - b}$$

$$\Rightarrow x = \frac{b^2 + 1}{-(b + 1)} = \frac{-(b + 1)}{1 - b}$$

$$\Rightarrow (b^2 + 1)(1 - b) = (b + 1)^2$$

$$\Rightarrow b^2 - b^3 + 1 - b = b^2 + 2b + 1$$

$$\Rightarrow b^3 + 3b = 0$$

$$\Rightarrow b = 0 ; b^2 = -3$$

$$\Rightarrow b = 0, \pm\sqrt{3}i$$

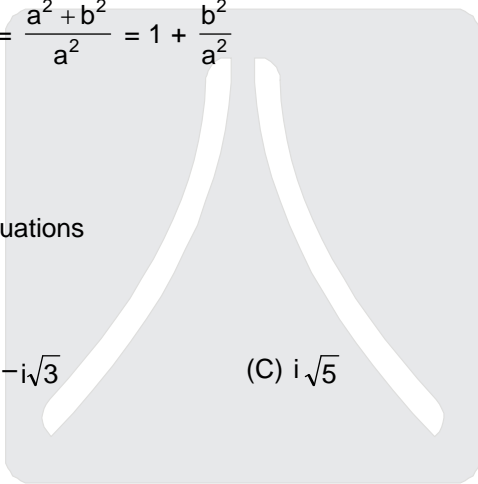

43. Let $\omega \neq 1$ be a cube root of unity and S be the set of all non-singular matrices of the form

$$\begin{bmatrix} 1 & a & b \\ \omega & 1 & c \\ \omega^2 & \omega & 1 \end{bmatrix},$$

where each of a, b and c is either ω or ω^2 . Then the number of distinct matrices in the set S is
 (A) 2 (B) 6 (C) 4 (D) 8

Ans. (A)

Sol. a, b, c $\in \{\omega, \omega^2\}$

$$\text{Let } A = \begin{bmatrix} 1 & a & b \\ \omega & 1 & c \\ \omega^2 & \omega & 1 \end{bmatrix}$$

$$\Rightarrow |A| = 1 - (a + c)\omega + ac\omega^2$$

Now |A| will be non-zero

only when a = c = ω

$$\therefore (a, b, c) \equiv (\omega, \omega, \omega) \text{ or } (\omega, \omega^2, \omega)$$

$$\therefore \text{number of non singular matrices} = 2$$

44. The circle passing through the point $(-1, 0)$ and touching the y-axis at $(0, 2)$ also passes through the point

- (A) $\left(-\frac{3}{2}, 0\right)$ (B) $\left(-\frac{5}{2}, 2\right)$ (C) $\left(-\frac{3}{2}, \frac{5}{2}\right)$ (D) $(-4, 0)$

Ans. (D)

Sol. Let equation of circle is

$$x^2 + y^2 + 2gx + 2fy + c = 0$$

as it passes through $(-1, 0)$ & $(0, 2)$

$$\therefore 1 - 2g + c = 0$$

$$\text{and } 4 + 4f + c = 0$$

$$\text{also } f^2 = c$$

$$\Rightarrow f = -2, c = 4; g = \frac{5}{2}$$

\therefore equation of circle is

$$x^2 + y^2 + 5x - 4y + 4 = 0$$

which passes through $(-4, 0)$

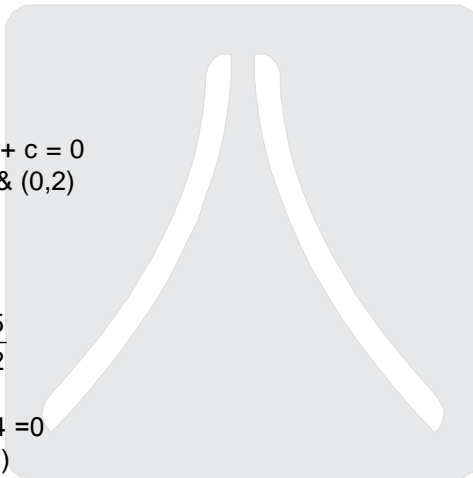

45. If $\lim_{x \rightarrow 0} [1 + x \ln(1 + b^2)]^{\frac{1}{x}} = 2b \sin^2 \theta$, $b > 0$ and $\theta \in (-\pi, \pi]$, then the value of θ is

- (A) $\pm \frac{\pi}{4}$ (B) $\pm \frac{\pi}{3}$ (C) $\pm \frac{\pi}{6}$ (D) $\pm \frac{\pi}{2}$

Ans. (D)

Sol. $\lim_{x \rightarrow 0} e^{\frac{x \ln(1+b^2)}{x}} = 1 + b^2 = 2b \sin^2 \theta$

$$\Rightarrow \sin^2 \theta = \frac{1}{2} \left(b + \frac{1}{b} \right)$$

We know $b + \frac{1}{b} \geq 2$

$$\Rightarrow \sin^2 \theta \geq 1 \quad \text{but} \quad \sin^2 \theta \leq 1$$

$$\Rightarrow \sin^2 \theta = 1 \quad \Rightarrow \quad \theta = \pm \frac{\pi}{2}$$

46. Let $f : [-1, 2] \rightarrow [0, \infty)$ be a continuous function such that $f(x) = f(1 - x)$ for all $x \in [-1, 2]$.

Let $R_1 = \int_{-1}^2 x f(x) dx$, and R_2 be the area of the region bounded by $y = f(x)$, $x = -1$, $x = 2$, and the x -axis.

Then

(A) $R_1 = 2R_2$

(B) $R_1 = 3R_2$

(C) $2R_1 = R_2$

(D) $3R_1 = R_2$

Ans. (C)

Sol. $R_2 = \int_{-1}^2 f(x) dx$ and $R_1 = \int_{-1}^2 x f(x) dx$

$$\Rightarrow = \int_{-1}^2 (1-x)f(1-x) dx$$

$$= \int_{-1}^2 (1-x)f(x) dx$$

$$\Rightarrow R_1 = R_2 - R_1$$

$$2R_1 = R_2$$

47. Let $f(x) = x^2$ and $g(x) = \sin x$ for all $x \in \mathbb{R}$. Then the set of all x satisfying $(f \circ g \circ g \circ f)(x) = (g \circ g \circ f)(x)$, where $(f \circ g)(x) = f(g(x))$, is

(A) $\pm \sqrt{n\pi}$, $n \in \{0, 1, 2, \dots\}$

(B) $\pm \sqrt{n\pi}$, $n \in \{1, 2, \dots\}$

(C) $\frac{\pi}{2} + 2n\pi$, $n \in \{\dots, -2, -1, 0, 1, 2, \dots\}$

(D) $2n\pi$, $n \in \{\dots, -2, -1, 0, 1, 2, \dots\}$

Ans. (A)

Sol. $f(x) = x^2$; $g(x) = \sin x$
 $g \circ f(x) = \sin x^2$

$$\Rightarrow g \circ g \circ f(x) = \sin(\sin x^2)$$

$$\Rightarrow (f \circ g \circ g \circ f)(x) = (\sin(\sin x^2))^2 = \sin^2(\sin x^2)$$

Now $\sin^2(\sin x^2) = \sin(\sin x^2)$

$$\Rightarrow \sin(\sin x^2) = 0, 1$$

$$\Rightarrow \sin x^2 = n\pi, (4n+1) \frac{\pi}{2}; \quad \eta \in \mathbb{I}$$

$$\Rightarrow \sin x^2 = 0$$

$$\Rightarrow x^2 = n\pi$$

$$\Rightarrow x = \pm \sqrt{n\pi}; \quad n \in \mathbb{W}$$

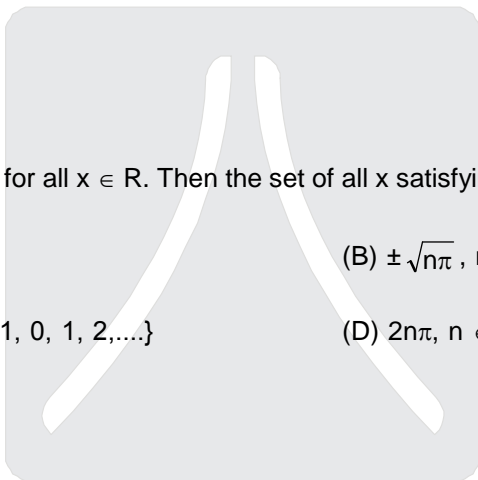

Resonance
Where you will be in resonance with IIT-JEE

(D) at $x = -\frac{3}{2} > -\frac{\pi}{2}$
 $\Rightarrow f(x) = -\cos x$
 \Rightarrow differentiable at $x = -\frac{3}{2}$

50. Let E and F be two independent events. The probability that exactly one of them occurs is $\frac{11}{25}$ and the probability of none of them occurring is $\frac{2}{25}$. If P(T) denotes the probability of occurrence of the event T, then

(A) $P(E) = \frac{4}{5}, P(F) = \frac{3}{5}$

(B) $P(E) = \frac{1}{5}, P(F) = \frac{2}{5}$

(C) $P(E) = \frac{2}{5}, P(F) = \frac{1}{5}$

(D) $P(E) = \frac{3}{5}, P(F) = \frac{4}{5}$

Ans. (A, D)

Sol. $P(E \cap F) = P(E) \cdot P(F) \dots(1)$

$P(E \cap \bar{F}) + P(\bar{E} \cap F) = \frac{11}{25} \dots(2)$

$P(\bar{E} \cap \bar{F}) = \frac{2}{25} \dots(3)$

by (2)

$P(F) + P(E) - 2P(E \cap F) = \frac{11}{25} \dots(4)$

by (3)

$1 - [P(E) + P(F) - P(E \cap F)] = \frac{2}{25}$

$[P(E) + P(F) - P(E \cap F)] = \frac{23}{25} \dots(5)$

by (4) & (5) $P(E) P(F) = \frac{12}{25} \dots(6)$

and $P(E) + P(F) = \frac{7}{5} \dots(7)$

By (6) and (7) $P(E) = \frac{4}{5}, P(F) = \frac{3}{5}$ or $P(E) = \frac{3}{5}, P(F) = \frac{4}{5}$

51. Let L be a normal to the parabola $y^2 = 4x$. If L passes through the point (9, 6), then L is given by
 (A) $y - x + 3 = 0$ (B) $y + 3x - 33 = 0$ (C) $y + x - 15 = 0$ (D) $y - 2x + 12 = 0$

Ans. (A, B, D)

$$= \frac{(a+b+c)(\bar{a} + \bar{b} + \bar{c}) + (a+b\omega+c\omega^2)(\bar{a} + \bar{b}\omega^2 + \bar{c}\omega) + (a+b\omega^2+c\omega)(\bar{a} + \bar{b}\omega + \bar{c}\omega^2)}{|a|^2 + |b|^2 + |c|^2}$$

$$= \frac{3(|a|^2 + |b|^2 + |c|^2)}{|a|^2 + |b|^2 + |c|^2} = 3$$

54. The number of distinct real roots of $x^4 - 4x^3 + 12x^2 + x - 1 = 0$ is

Ans. 2

Sol. $f(x) = x^4 - 4x^3 + 12x^2 + x - 1$
 $f'(x) = 4x^3 - 12x^2 + 24x + 1$
 $f''(x) = 12x^2 - 24x + 24$
 $= 12(x^2 - 2x + 2) > 0 \quad \forall x \in \mathbb{R}$
 $\therefore f'(x)$ is S.I. function
 Let α is a real root of the equation $f'(x) = 0$
 $\therefore f(x)$ is MD for $x \in (-\infty, \alpha)$ and M.I. for $x \in (\alpha, \infty)$
 where $\alpha < 0$
 $\therefore f(0) = -1$ and $\alpha < 0$
 $\Rightarrow f(\alpha)$ is also negative
 $\therefore f(x) = 0$ has two real & distinct roots.

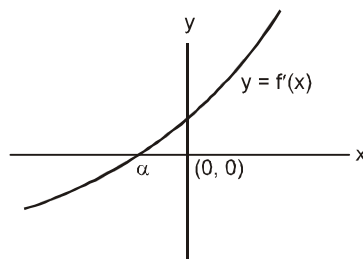

55. Let $y'(x) + y(x) g'(x) = g(x) g'(x)$, $y(0) = 0$, $x \in \mathbb{R}$, where $f'(x)$ denotes $\frac{df(x)}{dx}$ and $g(x)$ is a given non-constant differentiable function on \mathbb{R} with $g(0) = g(2) = 0$. Then the value of $y(2)$ is

Ans. 0

Sol. $y'(x) + y(x) g'(x) = g(x) g'(x)$, $y(0) = 0 \quad \forall x \in \mathbb{R}$
 $\frac{d}{dx} (y(x)) + y(x) g'(x) = g(x) g'(x)$, $g(0) = g(2) = 0$.

$$I \cdot F = e^{\int g'(x) dx} = e^{g(x)}$$

$$y(x) e^{g(x)} = \int e^{g(x)} g(x) g'(x) dx + c$$

$$\text{Let } g(x) = t \\ g'(x) dx = dt$$

$$y(x) e^{g(x)} = \int t e^t dt \\ = t e^t - e^t + c$$

$$y(x) = (g(x) - 1) + c e^{-g(x)}$$

$$\text{Let } x = 0 \quad y(0) = (g(0) - 1) + c e^{-g(0)}$$

$$0 = (0 - 1) + c \Rightarrow c = 1$$

$$y(x) = (g(x) - 1) + e^{-g(x)}$$

$$y(2) = (g(2) - 1) + e^{-g(2)}$$

$$y(2) = (0 - 1) + e^{-0} = -1 + 1 = 0$$

56. Let M be a 3×3 matrix satisfying

$$M \begin{bmatrix} 0 \\ 1 \\ 0 \end{bmatrix} = \begin{bmatrix} -1 \\ 2 \\ 3 \end{bmatrix}, M \begin{bmatrix} 1 \\ -1 \\ 0 \end{bmatrix} = \begin{bmatrix} 1 \\ 1 \\ -1 \end{bmatrix}, \text{ and } M \begin{bmatrix} 1 \\ 1 \\ 1 \end{bmatrix} = \begin{bmatrix} 0 \\ 0 \\ 12 \end{bmatrix}. \text{ Then the sum of the diagonal entries of M is}$$

Ans. 9

Sol. Let $M = \begin{bmatrix} a_{11} & a_{12} & a_{13} \\ a_{21} & a_{22} & a_{23} \\ a_{31} & a_{32} & a_{33} \end{bmatrix}$

then $a_{12} = -1,$

$a_{22} = 2,$

$a_{32} = 3,$

$a_{11} - a_{12} = 1 \Rightarrow a_{11} = 0,$

$a_{21} - a_{22} = 1 \Rightarrow a_{21} = 3,$

$a_{31} - a_{32} = 1 \Rightarrow a_{31} = 2,$

$a_{11} + a_{12} + a_{13} = 0 \Rightarrow a_{13} = 1$

$a_{21} + a_{22} + a_{23} = 0 \Rightarrow a_{23} = -5$

$a_{31} + a_{32} + a_{33} = 12 \Rightarrow a_{33} = 7$

Hence sum of diagonal of M is $= a_{11} + a_{22} + a_{33} = 0 + 2 + 7 = 9$

57. Let $\vec{a} = -\hat{i} - \hat{k}, \vec{b} = -\hat{i} + \hat{j}$ and $\vec{c} = \hat{i} + 2\hat{j} + 3\hat{k}$ be three given vectors. If \vec{r} is a vector such that $\vec{r} \times \vec{b} = \vec{c} \times \vec{b}$ and $\vec{r} \cdot \vec{a} = 0$, then the value of $\vec{r} \cdot \vec{b}$ is

Ans. 9

Sol. $(\vec{r} - \vec{c}) \times \vec{b} = 0$

$\vec{r} - \vec{c} = \lambda \vec{b} \Rightarrow \vec{r} = \vec{c} + \lambda \vec{b} \quad \lambda \in \mathbb{R}$

$\therefore \vec{r} \cdot \vec{a} = 0$

$\Rightarrow (\vec{c} + \lambda \vec{b}) \cdot \vec{a} = 0$

$\Rightarrow ((\hat{i} + 2\hat{j} + 3\hat{k}) + \lambda(-\hat{i} + \hat{j})) \cdot (-\hat{i} - \hat{k}) = 0$

$\Rightarrow ((1 - \lambda)\hat{i} + (2 + \lambda)\hat{j} + 3\hat{k}) \cdot (-\hat{i} - \hat{k}) = 0$

$\Rightarrow \lambda - 1 - 3 = 0$

$\Rightarrow \lambda = 4$

so $\vec{r} \cdot \vec{b} = (-3\hat{i} + 6\hat{j} + 3\hat{k}) \cdot (-\hat{i} + \hat{j})$

$= 3 + 6 = 9$

58. The straight line $2x - 3y = 1$ divides the circular region $x^2 + y^2 \leq 6$ into two parts.

If $S = \left\{ \left(2, \frac{3}{4} \right), \left(\frac{5}{2}, \frac{3}{4} \right), \left(\frac{1}{4}, -\frac{1}{4} \right), \left(\frac{1}{8}, \frac{1}{4} \right) \right\}$,

then the number of point(s) in S lying inside the smaller part is

Sol. $2x - 3y = 1, x^2 + y^2 \leq 6$

$S = \left\{ \left(2, \frac{3}{4} \right), \left(\frac{5}{2}, \frac{3}{4} \right), \left(\frac{1}{4}, -\frac{1}{4} \right), \left(\frac{1}{8}, \frac{1}{4} \right) \right\}$
 (I) (II) (III) (IV)

Plot the two curves

I, III, IV will lie inside the circle and point (I, III, IV) will lie on the P region if (0, 0) and the given point will lie opposite to the line $2x - 3y - 1 = 0$

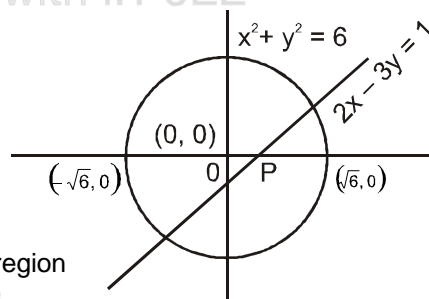

$P(0, 0) = \text{negative}$, $P\left(2, \frac{3}{4}\right) = \text{positive}$, $P\left(\frac{1}{4}, -\frac{1}{4}\right) = \text{positive}$ $P\left(\frac{1}{8}, \frac{1}{4}\right) = \text{negative}$

$P\left(\frac{5}{2}, \frac{3}{4}\right) = \text{positive}$, but it will not lie in the given circle

so point $\left(2, \frac{3}{4}\right)$ and $\left(\frac{1}{4}, -\frac{1}{4}\right)$ will lie on the opp side of the line

so two point $\left(2, \frac{3}{4}\right)$ and $\left(\frac{1}{4}, -\frac{1}{4}\right)$

Further $\left(2, \frac{3}{4}\right)$ and $\left(\frac{1}{4}, -\frac{1}{4}\right)$ satisfy $S_1 < 0$

SECTION - IV (Total Marks : 16)

(Matrix-Match Type)

This section contains **2 questions**. Each question has **four statements** (A, B, C and D) given in **Column-I** and **five statements** (p, q, r, s and t) in **Column-II**. Any given statement in Column-I can have correct matching with **ONE** or **MORE** statement(s) given in Column-II. For example, if for a given question, statement B matches with the statements given in q and r, then for the particular question, against statement B, darken the bubbles corresponding to q and r in the ORS.

59. Match the statements given in **Column-I** with the values given in **Column-II**

Column-I

Column-II

(A) If $\vec{a} = \hat{j} + \sqrt{3}\hat{k}$, $\vec{b} = -\hat{j} + \sqrt{3}\hat{k}$ and $\vec{c} = 2\sqrt{3}\hat{k}$ form a triangle, then the internal angle of the triangle between \vec{a} and \vec{b} is

(p) $\frac{\pi}{6}$

(B) If $\int_a^b (f(x) - 3x) dx = a^2 - b^2$, then the value of $f\left(\frac{\pi}{6}\right)$ is

(q) $\frac{2\pi}{3}$

(C) The value of $\frac{\pi^2}{\ln 3} \int_{7/6}^{5/6} \sec(\pi x) dx$ is

(r) $\frac{\pi}{3}$

(D) The maximum value of $\left| \text{Arg}\left(\frac{1}{1-z}\right) \right|$ for $|z| = 1, z \neq 1$ is given by

(s) π

(t) $\frac{\pi}{2}$

Ans. (A) \rightarrow (q), (B) \rightarrow (p), (C) \rightarrow (s), (D) \rightarrow (t)

Sol. (A) $\cos(\pi - \theta) = \frac{\vec{a} \cdot \vec{b}}{|\vec{a}| |\vec{b}|} = \frac{-1+3}{\sqrt{1+3}\sqrt{1+3}} = \frac{2}{4}$

$-\cos\theta = \frac{1}{2}$

$\theta = \frac{2\pi}{3}$

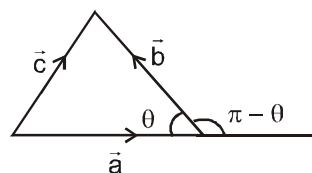

(B) Using Leibnitz Theorem

$$f(b) - 3b = -2b$$

$$f(b) = b$$

(C)
$$\frac{\pi^2}{\ln 3} \int_{7/6}^{5/6} (\sec \pi x) dx = \frac{\pi^2}{\ln 3} \left\{ \frac{\ln |\sec \pi x + \tan \pi x|}{\pi} \right\}_{7/6}^{5/6}$$

$$= \frac{\pi^2}{\ln 3} \left\{ \frac{\ln \left| -\frac{2}{\sqrt{3}} - \frac{1}{\sqrt{3}} \right|}{\pi} - \ln \left| -\frac{2}{3} + \frac{1}{\sqrt{3}} \right| \right\} = \frac{\pi^2}{\ln 3} \left\{ \frac{\ln \left| \frac{3}{\sqrt{3}} \times \frac{\sqrt{3}}{1} \right|}{\pi} \right\} = \pi$$

(D) z ($z \neq 1$) lies on circle with center 0, radius 1

$$\text{Arg} \left(\frac{1}{1-z} \right) = \text{Arg} 1 - \text{Arg} (1-z) = \text{angle between OA and BA}$$

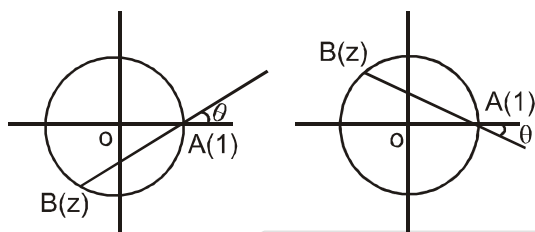

Absolute value of angle between OA and BA tends to $\frac{\pi}{2}$ as B tends to A.

Alter # 1

$$\left| \arg \left(\frac{1}{1-z} \right) \right| = |\arg 1 - \arg (1-z)| = |\arg (1-z)|$$

as $|z| = 1$ i.e. z lies on circle



$\Rightarrow -z$ lies on circle

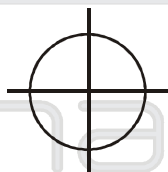

$\Rightarrow 1-z$ lies on circle

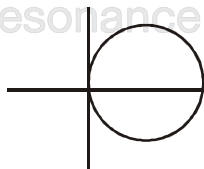

$\Rightarrow \max |\arg (1-z)| = \frac{\pi}{2}$

Alter # 2

$$z = e^{i\theta}$$

$$\frac{1}{1-z} = \frac{1}{2\sin^2 \frac{\theta}{2} - i\sin\theta} = \frac{1}{2\sin \frac{\theta}{2}} \left(\sin \frac{\theta}{2} + i\cos \frac{\theta}{2} \right) = \frac{1}{2} + i \frac{1}{2} \cot \frac{\theta}{2}$$

Locus is $\frac{1}{1-z}$ is $x = \frac{1}{2}$

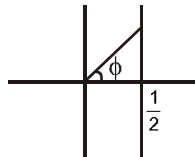

Maximum value of ϕ tends to $\frac{\pi}{2}$

60. Match the statements given in **Column-I** with the intervals/union of intervals given in **Column-II**

Column-I

Column-II

(A) The set $\left\{ \operatorname{Re} \left(\frac{2iz}{1-z^2} \right) : z \text{ is a complex number, } |z|=1, z \neq \pm 1 \right\}$ is (p) $(-\infty, -1) \cup (1, \infty)$

(B) The domain of the function $f(x) = \sin^{-1} \left(\frac{8(3)^{x-2}}{1-3^{2(x-1)}} \right)$ is (q) $(-\infty, 0) \cup (0, \infty)$

(C) If $f(\theta) = \begin{vmatrix} 1 & \tan \theta & 1 \\ -\tan \theta & 1 & \tan \theta \\ -1 & -\tan \theta & 1 \end{vmatrix}$, (r) $[2, \infty)$

then the set $\left\{ f(\theta) : 0 \leq \theta < \frac{\pi}{2} \right\}$ is

(D) If $f(x) = x^{3/2} (3x - 10)$, $x \geq 0$, then $f(x)$ is increasing in (s) $(-\infty, -1] \cup [1, \infty)$

(t) $(-\infty, 0] \cup [2, \infty)$

Ans. (A) \rightarrow (s), (B) \rightarrow (t), (C) \rightarrow (r), (D) \rightarrow (r)

Sol. (A) $\operatorname{Re} \left(\frac{2i(x+iy)}{1-(x^2-y^2+2xyi)} \right) = \operatorname{Re} \left(\frac{-2y+2ix}{1-x^2+y^2-2xyi} \right) = \operatorname{Re} \left(\frac{-2y+2ix}{2y(y-ix)} \right) = \operatorname{Re} (-1/y) = \frac{-1}{y}$

$$= -1 \leq y \leq 1 = \frac{-1}{y} \geq 1 \text{ or } \frac{-1}{y} \leq -1$$

Alternate

$$\operatorname{Re} \left(\frac{2ie^{i\theta}}{1-e^{2i\theta}} \right) = \operatorname{Re} \left(\frac{2i(\cos \theta + i\sin \theta)}{1-(\cos 2\theta + i\sin 2\theta)} \right)$$

$$= \operatorname{Re} \left(\frac{2i(\cos \theta + i\sin \theta)}{2\sin^2 \theta - 2i\sin \theta \cos \theta} \right) = \operatorname{Re} \left(\frac{i(\cos \theta + i\sin \theta)}{\sin \theta(\sin \theta - i\cos \theta)} \right) = \operatorname{Re} \left(\frac{(\cos \theta + i\sin \theta)}{-\sin \theta(\cos \theta + i\sin \theta)} \right)$$

$$= \operatorname{Re} \left(\frac{-1}{\sin \theta} \right)$$

as $-1 \leq \sin \theta \leq 1$
 $(-\infty, 0) \cup (0, \infty)$

(B) $-1 \leq \frac{8 \cdot 3^{x-2}}{1-3^{2x-2}} \leq 1 \Rightarrow -1 \leq \frac{8t}{9-t^2} \leq 1$

$\Rightarrow -1 \leq \frac{8t}{9-t^2} \leq 1 \Rightarrow 0 \leq \frac{9-t^2+8t}{9-t^2} \cap \frac{8t}{9-t^2} - 1 \leq 0$

$\Rightarrow 0 \leq \frac{t^2-8t-9}{t^2-9} \cap \frac{8t-9+t^2}{9-t^2} \leq 0 \Rightarrow 0 \leq \frac{(t-9)(t+1)}{(t-3)(t+3)} \cap \frac{(t+9)(t-1)}{(t-3)(t+3)} \geq 0$

$\Rightarrow t \in (-\infty, -9] \cup [-1, 1] \cup [9, \infty) \Rightarrow x \in (-\infty, 0) \cup [2, \infty)$

(C) $f(\theta) = 2 \sec^2 \theta$
 $\Rightarrow f(\theta) \geq 2$
 $\Rightarrow f(\theta) \in [2, \infty)$

(D) $f(x) = x^{3/2} (3x - 10)$
 $\Rightarrow f'(x) = x^{3/2} \cdot 3 + \frac{3}{2} x^{1/2} (3x - 10)$

as $f'(x) \geq 0$

$\Rightarrow x^{1/2} \left[3x + \frac{3}{2} (3x - 10) \right] \geq 0$

$\Rightarrow 3x + \frac{9x}{2} - 15 \geq 0$

$\Rightarrow \frac{15x}{2} - 15 \geq 0$

$\Rightarrow x \geq 2$

$\Rightarrow x \in [2, \infty)$

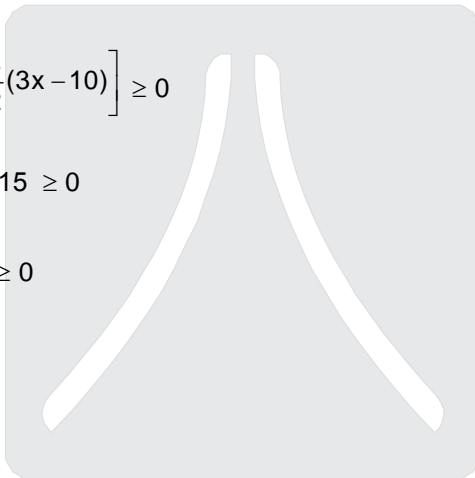

Resonance
 Where you will be in resonance with IIT-JEE

Name of the Candidate

Roll Number

--	--	--	--	--	--	--

I have read all the instructions
and shall abide by them.

Signature of the Candidate

I have verified all the informa-
tion filled in by the Candidate.

Signature of the Invigilator

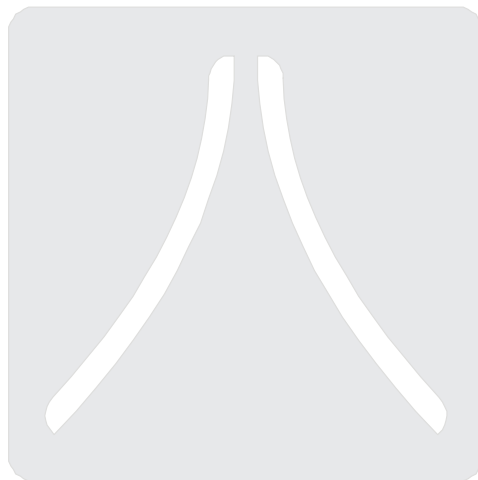

Resonance

Where you will be in resonance with IIT-JEE